

4-10 CARTRIDGE POSITION ADJUSTMENT

4 Press the [HEAD CUT] key to enter the CARTRIDGE POSITION ADJUSTMENT MODE.



This adjustment is required to adjust the position of the THERMAL CARRIAGE in order to pick up the RIBBON CARTRIDGE correctly. It is necessary when the THERMAL CARRIAGE, CARTRIDGE HOLDER and the MAIN BOARD are replaced.

- 1 Turn on the SUB POWER SW while pressing the [HEAD CLEANING] and [BASE POINT] keys to enter the FACTORY MODE.

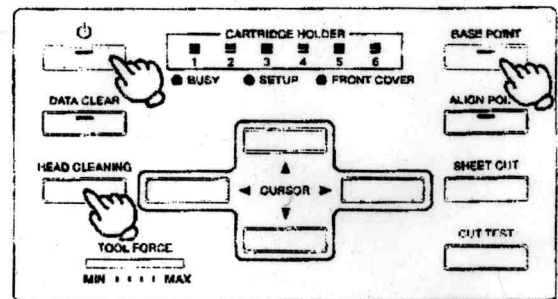

- 2 Make the [HOLDER 6] LED to blink by pressing the [RIGHT] key 7 times.

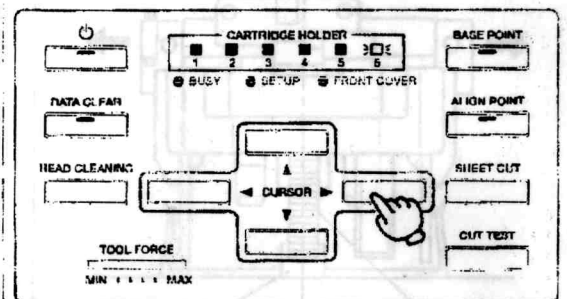

- 3 Press the [HEAD CLEANING] key.

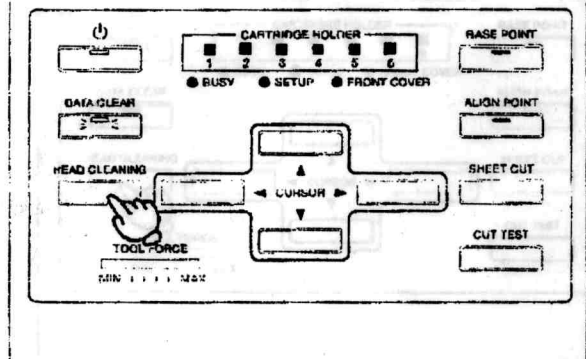

- 4 Press the [SHEET CUT] key to enter the CARTRIDGE POSITION ADJUSTMENT MODE.

Both the [DATA CLEAR] and [ALIGN POINT] LEDs light up.

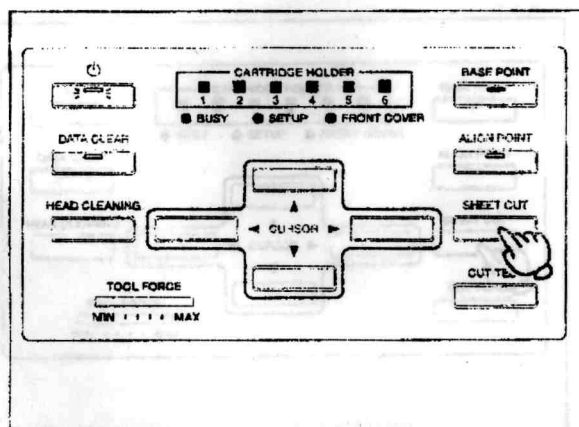

- 5 Close the FRONT COVER.

HEAD CARRIAGE moves and stops at CARTRIDGE HOLDER 4.

- 6 Adjust the position of the THERMAL CARRIAGE with [◀] and [▶] keys so that the WHITE GEAR on the THERMAL CARRIAGE comes at the center of the CARTRIDGE HOLDER 4.

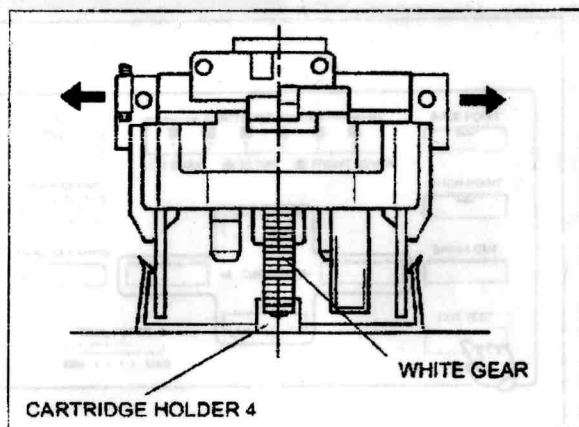

- 7 Press the [HEAD CLEANING] key to save the settings. [DATA CLEAR] and [ALIGN POINT] LEDs light up when it is saved.

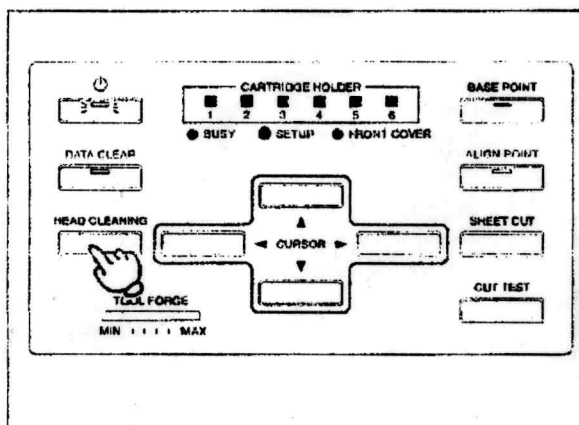

- 8** Open the FRONT COVER and press the [SHEET CUT] key to end the CARTRIDGE POSITION ADJUSTMENT MODE. THERMAL CARRIAGE moves to the CARTRIDGE HOLDER 2 and the [DATA CLEAR] and the [SUPER POWER] LEDs light up.

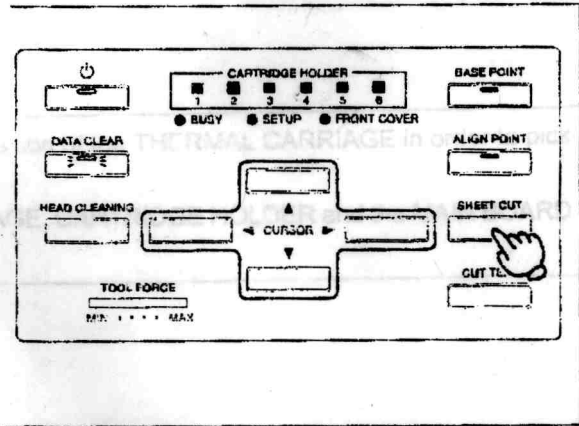

- 9** Put the RIBBON CARTRIDGE only on the CARTRIDGE HOLDER 1.

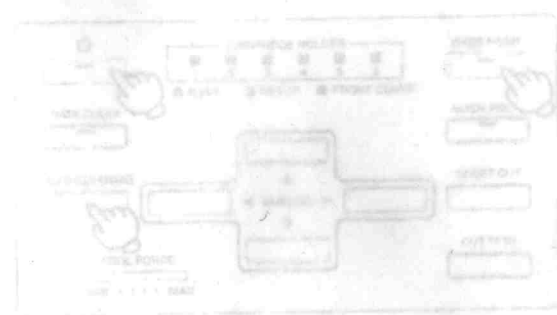

- 10** Close the FRONT COVER while pressing the [CUT TEST] key. [DATA CLEAR] and the [BUSY] LEDs start blinking.

THERMAL CARRIAGE starts the EXCHANGE TEST with the following patterns.

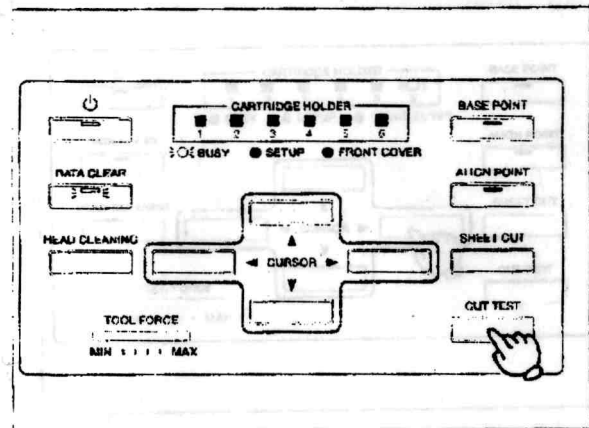

- 11** When the CARTRIDGE EXCHANGE TEST is performed correctly in all the above 3 patterns, open the FRONT COVER and finish the CARTRIDGE POSITION ADJUSTMENT MODE.

If NG, try it over again from **6**.

